

Pana40 Plus 2D / 3D Elevator Light Curtains

Product Datasheet



The Pana40 Plus safety detection system offers maximum passenger protection. The traditional 2D infra-red light curtain is also available in 3D detection to offer additional protection in the landing zone.

Any object causing interruption of the direct beams or reflections within the 3D detection zone will trigger the system and re-open the elevator doors.

The 77X or 3D detectors can be used with all 3D versions of the Pana40Plus controller. These controllers are available in 40 or 194 beam pattern versions and for various supply voltages (AC or DC).

The system can be configured for different operating modes to suit particular installation needs. For example the '3D Timeout' mode is ideal for hospitals because the doors will only start to close if the 3D detection zone is clear and the timer has expired.

The 3D detector range is equal to approximately half the door separation. As the doors close the 3D detection zone moves inward giving increasingly sensitive protection to the door aperture.

Key Features

- + Complies with EN81-20 and EN81-70 legislation
- + Vandal resistant fixtures designed for fast installation
- + 40 parallel or 194 criss-cross beams offer protection up to a height of 1.8m
- + Suitable for centre-opening and side-opening doors
- + Self-drilling screw for fast, easy fixing
- + 2D Light immunity to over 100,000 lux

Detector Profiles

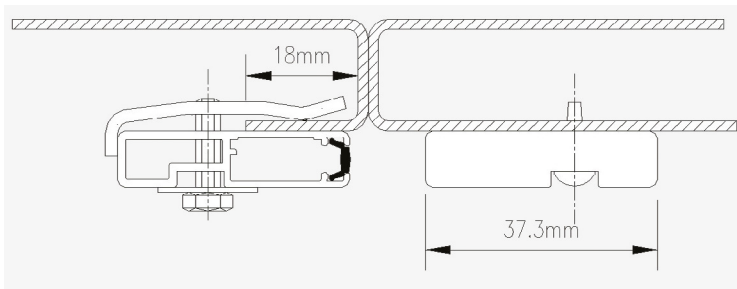

Fig 1: 743 000 Fixing Clamp and Self-Tapping Screw

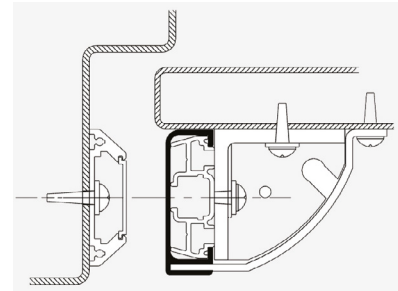

Fig 2: 744 020 Self-Tapping Screw and standard fixing

The Pana40 Plus detector range is suitable for both side-opening and centre-opening doors and has a wide range of profiles to suit most installations. The detectors are supplied with appropriate fixing kits for up to 5 types of installation. They are designed for fast installation with no alignment problems.

The mechanical design of the profiles ensures simple installation methods, with high impact strength and ingress protection against dust and water

The custom-designed lens used on this range optimises the beam profile and can be used with either the Pana40 Plus or Pana194 controllers to generate a 40 beam or 194 beam pattern respectively. The beams offer protection to 1.8m height to fully comply with legislation. The diagnostic LED assists Service

Engineers in reducing call-out times.

3D Features:

- + 3D 'zone' gives extended protection into the landing (See below)
- + Selectable modes of 3D operation to suit various installation sites
- + 3D greatly reduces the chances of passenger injury by the landing door
- + 3D reduces damage to landing doors from trolleys and hospital beds
- + Advanced 3D diagnostic self-check for engineers

Profiles Available

9mm Profile [Ultra Slim]

- + Suitable for virtually all lifts
- + 2D or 3D Profiles (3D is 10mm)
- + 40 beams/194 beams options

16mm Profile [Slim Line]

- + Suitable for centre-opening doors with a narrow running clearance.
- + 2D or 3D Profiles
- + 40 beams/194 beams options

43mm Profile [Standard]

- + Suitable for wider sill arrangements
- + Pre-drilled holes
- + 2D or 3D Profiles
- + 40 beams/194 beams options

40mm Profile [Slam Post]

- + Only available in 2D version 2m and 2.1m
- + 40 beams/194 beams options

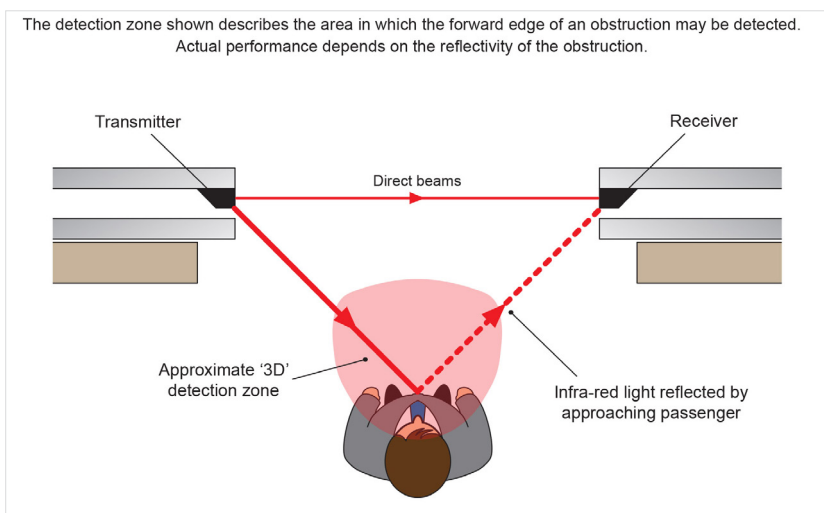

Fig 3

Accessories

- + Static Fixing Kit 616 800-010: This is necessary for installing a set of 9mm and 15mm profile detectors in a fixed position at either end of the lift car sill. See P40 Plus Detector installation guide.
- + Sightguards: These are designed to fit neatly over the Pana40 Plus range detectors and are available to suit elevators with different clearances.

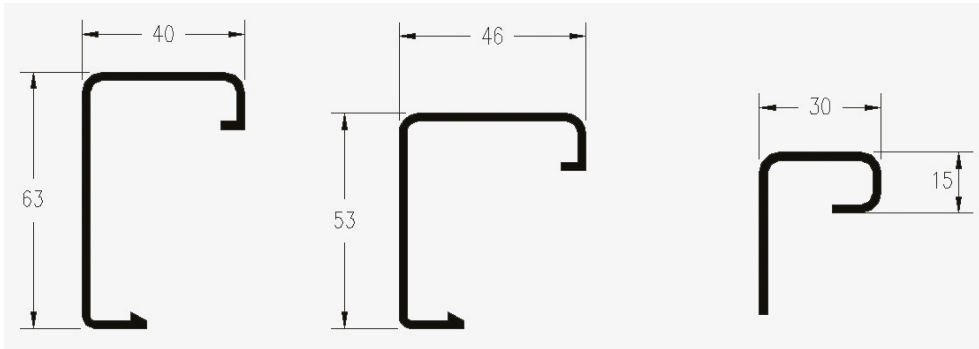

Fig 4: 007 035 40mm

Fig 5: 007 045 46mm

Fig 6: 007 065 30mm

- + FingerGuards: PVC FingerGuards are available to fill the 30mm gap found on some door types.

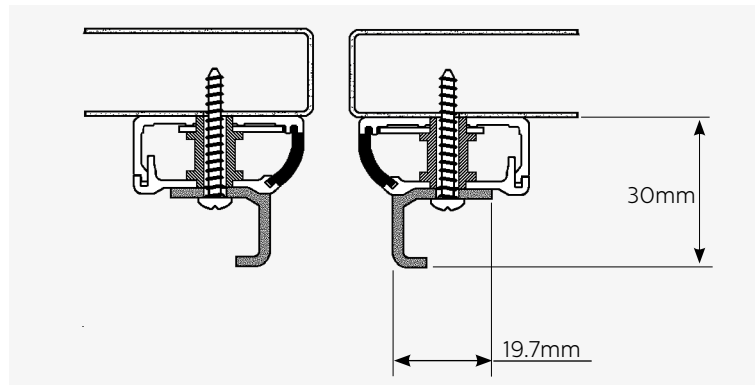

Fig 7

- + IGUS Chains: The Igus Chain is a snap-open energy chain which is placed around the extension cable to protect the detector cables from clamping when installed in a dynamic installation.

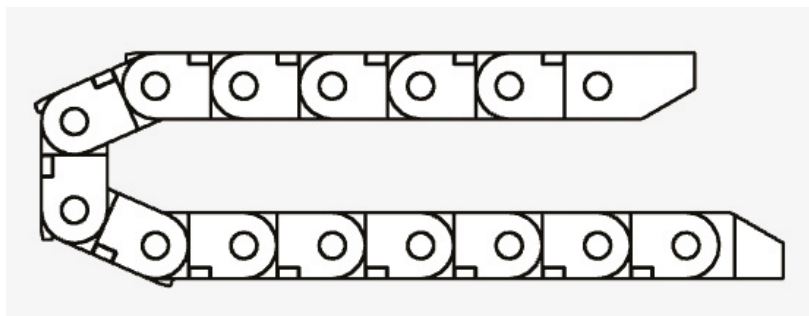

Fig 8

Technical Specification 2D

Product	740 040 Standard	741 000 Slimline	743 000 Ultra Slim	744 020 Mixed	744 010 Leading Edge	744 040 Slampost
Detector Size:	43mm x 63mm x 2100mm	15.5mm x 35mm x 2000mm	9mm x 37.3mm x 2000mm	740 = 43mm x 63mm x 2100mm 744 = 40mm x 10.7mm x 2100mm or 2300mm	40mm x 10.7mm x 2100mm	40mm x 10.7mm x 2000mm
Detector Cable Length:	750mm + 4m Extension Cables	750mm + 4m Extension Cables	750mm + 4m Extension Cables	740 = 750mm 744 = 1880mm + 4m Extension Cables	• 1880mm + 4m Extension Cables	1880mm + 4m Extension Cables
Diode Spacing:	45.7mm	45.7mm	45.7mm	45.7mm	45.7mm	45.7mm
Detector Range:	6m	6m	6m	6m	4m	4m
Number of Diodes Per Detector:	40	40	40	40	40	40
Number of Beams Per Detector:	40 Beams with Pana40+ Controller 194 Beams with Pana194+ Controller					
EMC Compliance:	Emissions to EN12015:2004, Immunity to EN12016:2004					
IP Rating:	IP54 as per EN60529:1991					
Vibration:	20-500Hz rms 4hrs 3 axis BS2011 Pt.2.2 Fd					

Technical Specification 3D

Product	770 040	771 000	774 000
Detector Size:	43.5mm x 62.5mm x 2100mm	15.5mm x 33.5mm x 2000mm	9.8mm x 37.3mm x 2000mm
Detector Cable Length:	725mm + 4m Extension Cables	665mm + 4m Extension Cables	725mm + 4m Extension
770 Detector Depth with rigid guard	63mm	-	-
2D Distance Between Bottom Beam & Bottom of Housing:	20mm For 2D Light Curtain	17mm For 2D Light Curtain	20mm For 2D Light Curtain
2D Distance Between Top Beam & Bottom of Housing:	1800mm 2D For Light Curtain	1800mm For 2D Light Curtain	1808mm For 2D Light Curtain
Maximum Range on 2D	6m	6m	5m
Maximum Range on 3D	Approx. 600mm from centre of doorway when doors are at 1200mm apart (Fig 3)	Approx. 600mm from centre of doorway when doors are at 1200mm apart (Fig 3)	Approx. 600mm from centre of doorway when doors are at 1200mm apart (Fig 3)
Number of Diodes Per Detector:	40	40	40
Number of Beams Per Detector:	40 Beams with Pana40+ Controller 194 Beams with Pana194+ Controller		

Ordering Information 2D and 3D

2D 74X Part Numbers and Description	Fixing Kits
740 040 – Universal	2x Fixing Kits for Standard Installations & 2x Fixing Kits for Leading Edge Installations
741 000 Slimline Detectors	2x Fixing Kits
743 000 Ultraslim Detectors	2x Fixing Kits
744 020 Mixed Slampost	1x Fixing Kit for Standard Installation & 1x Fixing Kit for Slampost Installation
744 010 Leading Edge Detectors	2x Fixing Kits for Leading Edge Installations
744 040 Slampost Detectors	2x Fixing Kits for Slampost Installations
3D 77X Part Numbers & Description	Fixing Kits
770 040 – Universal	2x Fixing Kits for Standard Installations & 2x Fixing Kits for Leading Edge Installations
771 000 – Slimline Detectors	2x Fixing Kits
774 000 – Ultra Slim Detectors	2x Fixing Kits
Spares & Accessories Part Numbers	Description
007 137	PVC Finger Guard for RX Slimline Detector 771 only – Right Hand Side
007 138	PVC Finger Guard for TX Slimline Detector 771 only – Left Hand Side
007 065	PVC Finger Guard for Slimline Detector 741 Universal
015 199	4m Extension Cable

This product is designed for use in elevators with powered automatic doors where the closing energy is less than 10J in normal operation and less than 4J during de-activation of the light curtains or less as per EN81 requirements. It should be installed by qualified personnel only, therefore any use outside of this application is at the installer's own risk and should be assessed appropriately.

As a result of our policy of continual improvement, the information in this document is subject to change without notice and it is intended only as general guidance on product performance and suitability. This information shall not form part of any contract.

AVIRE

Memco is a brand of Avire

Avire Ltd

Unit 1, The Switchback
Gardner Road
Maidenhead
Berkshire
SL6 7RJ, UK

T: 01628 540100
F: 01628 621 947
E: sales.uk@avire-global.com
W: www.memco-global.com
W: www.avire-global.com