

# PREMIUM

Automatic horizontal sliding landing door  
Designed for medium - high traffic installations  
EN - 81.20 compliance

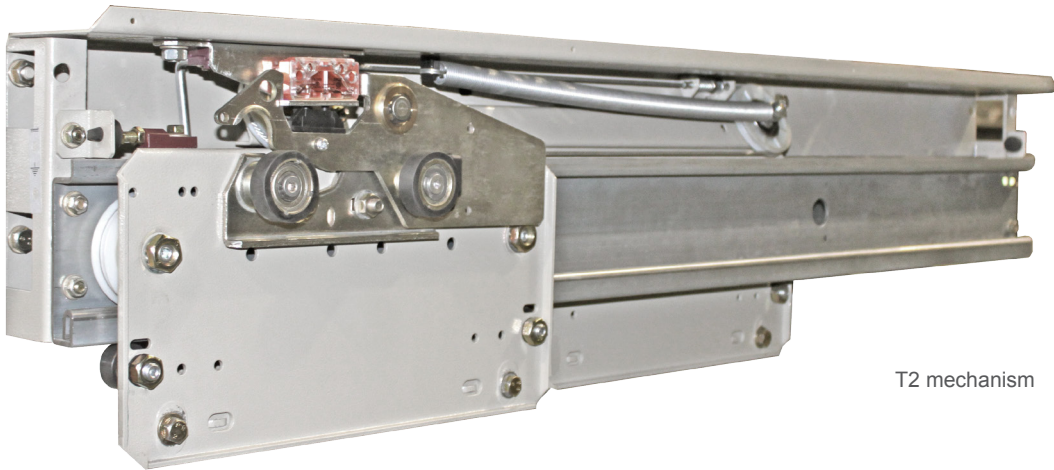

# Technical features



T2 mechanism

## GENERAL FEATURES

Noise level	46,2 dB
Total weight	88 kg (C2 CO 900 mm)
Safety closing system	With spring
	With counterweight (Optional) T1 - T2 - T3 Inside the jamb
	C2 - C4 - C6 Outside the mechanism. Maximum width increases 80 mm

## INSTALLATION

Pre-adjusted and tested to simplify the installation

## COUPLING: SKATES AND CAR DOOR LOCK

Asymmetric

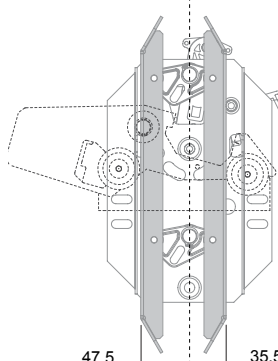

Automatic horizontal sliding car door  
Premium PM

## DOOR HOISTWAY PROJECTION (DHP) - FIXING BRACKETS

DHP type	C2		C4		C6		T1		T2		T3	
	DHP* (mm)	Bracket	DHP* (mm)	Bracket	DHP* (mm)	Bracket	DHP* (mm)	Bracket	DHP* (mm)	Bracket	DHP* (mm)	Bracket
1	0>31	X <sup>1</sup> - A <sup>2</sup>	0>37,5	X <sup>1</sup> - A <sup>2</sup>	0>32,5	D	0>31	X <sup>1</sup> - A <sup>2</sup>	0>37,5	X <sup>1</sup> - A <sup>2</sup>	0>32,5	D
2a	-	-	37,6>90	W	32,6>125	D	-	-	37,6>90	W	32,6>125	D
2b	32>93	W	91>140	D	126>175	V2	32>93	W	91>140	D	126>175	V2
3	94>124	V8	141>150	V2	176>195	V7	94>124	V8	141>150	V2	176>195	V7



\*See DHP dimension in sill detail (technical drawings pages)



#### Sales contacts

De Huchtstraat 41 – 1327 EC Almere  
Telefoon: 036 30 33 750

[Info@lmc-nl.nl](mailto:Info@lmc-nl.nl)  
[www.lmc-nl.nl](http://www.lmc-nl.nl)

IBAN: NL29 ABNA 0546 1812 36  
BIC: ABNANL2A

KvK-nummer: 61876593  
BTW-nummer: 854527771B01

**Elevating  
business.**